

INTERCAMBIABILIDAD Y DATOS DIMENSIONALES

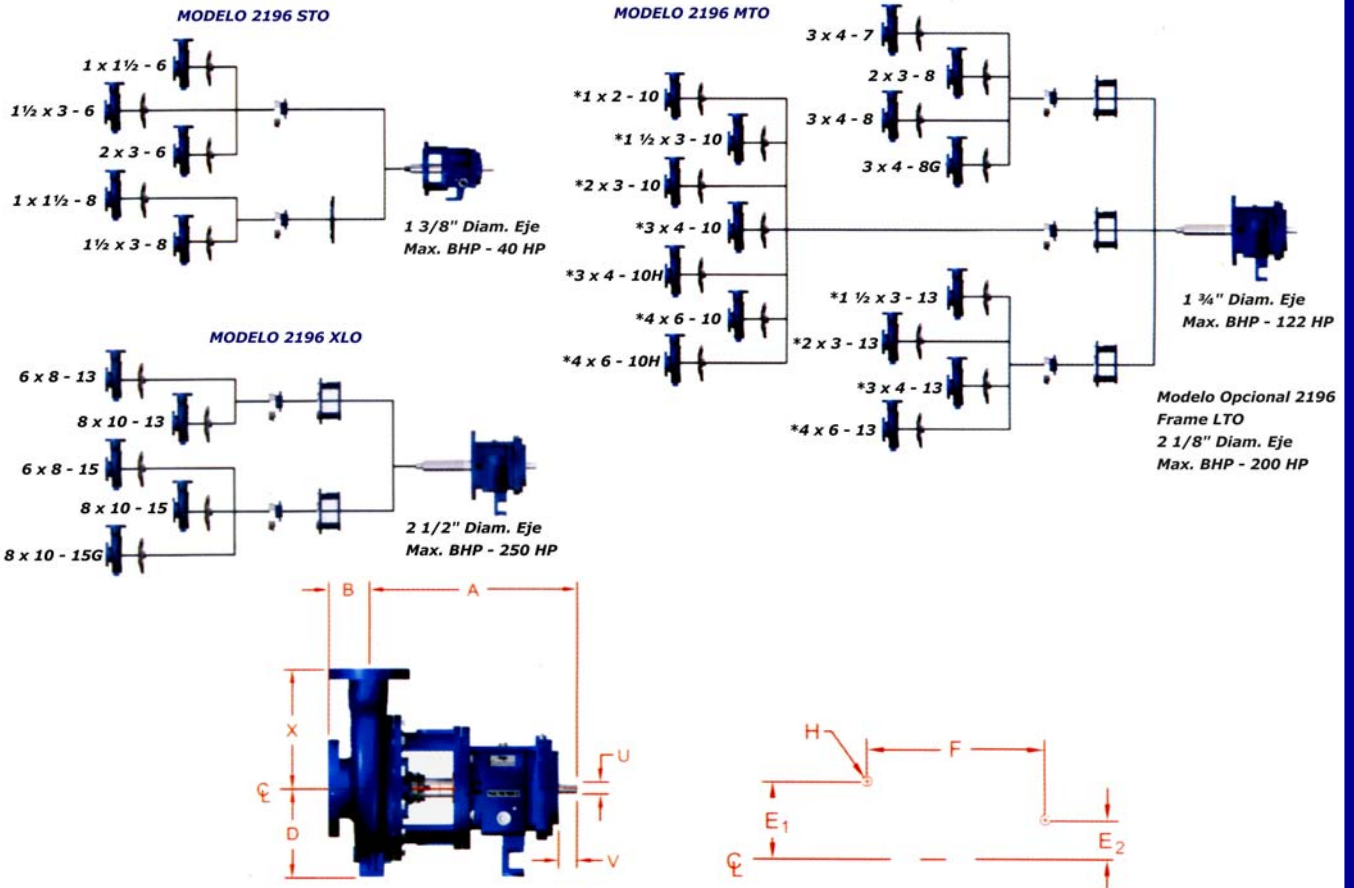

Pump Dimensions																	
Pump Frame	ANSI	Size			X	D	B	A	SP	Foot Pattern				Shaft			
		DIS	SUC	IMP						E1	E2	F	H	U	KEYWAY	V	
STO	AB	1	1.5	6	6 1/2	5 1/4	4	13 1/2	3 3/4	3	0	7 1/4	5/8	.875	3/16 x 3/32	2	
	AB	1.5	3	6													
	AA	1	1.5	8													
	AB	1.5	3	8													
MTO	A60	2	3	8	8 1/4	4	19 1/2	3 3/4	4 7/8	3 5/8	12 1/2	5/8	MTO	MTO	1.25	1/4 x 1/8	
	A70	3	4	8													11
	A70	3	4	8G													11
	A05	1	2	10													8 1/2
	A50	1.5	3	10													8 1/2
OR	A60	2	3	10	10	6	27 7/8	5 1/4	8	4 1/2	18 3/4	7/8	2.375	5/8 x 5/16	4		
	A70	3	4	10												11	
	A40	3	4	10H												12 1/2	
	A80	4	6	10												13 1/2	
LTO	A80	4	6	10H	13 1/2												
	A20	1.5	3	13	10 1/2												
	A30	2	3	13	11 1/2												
	A40	3	4	13	12 1/2												
XLO	A80	4	6	13	13 1/2												
	A90	6	8	13	16												
	A100	8	10	13	18												
	A110	6	8	15	18												
	A120	8	10	15	19												
A120	8	10	15G	19													

Diseño Gráfico: Rita Teixeira
 TRP/ANSI 2196 11/05/04